

# RA520 SERIES

## 400~500VA DC/AC INVERTERS Sine Wave Output



H114×W110×L310 (mm)

### Features

- High Efficiency 86~88% typ.
- 高効率 86~88% typical
- Wide Input Voltage Range
- 広範囲な入力電圧
- Input-Output Isolation (AC2000V)
- 入出力間絶縁 (AC2000V)
- High Reliability
- 高信頼性
- Output Frequency Temp. Coefficient  
0.01%/°C max.
- 出力周波数温度係数  
0.01%/°C 以下
- Remote ON/OFF Control
- リモートON/OFF制御
- Input Low Voltage Protection
- 入力低電圧保護回路内蔵
- Input Over Voltage Protection
- 入力過電圧保護回路内蔵
- Input Rush Current Protection  
(Input DC12V type is not built-in.)
- 入力突入電流保護回路内蔵  
(DC12V入力は除く)
- Thermal Protection  
+90°C~+110°C
- 過熱保護回路内蔵  
+90°C~+110°C
- Operating Ambient Temperature  
-25°C~+70°C
- 動作周囲温度  
-25°C~+70°C
- Built-in Input Fuse
- 入力ヒューズ内蔵
- Built-in Input and Output Noise Filter
- 入出力ノイズフィルタ内蔵
- Built-in Frequency Changing Switch  
(50Hz or 60Hz)
- 周波数切替スイッチ有り  
(50Hz又は60Hz)
- Conformity to RoHS2 Directive
- RoHS2指令対応

### General Characteristics

- Input Voltage (at Ta : 25°C, Full Load, Nominal Vin)  
DC12, 24, 48, 96V (See Table 1)
- Output Voltage  
AC100Vrms, ±1%  
AC200Vrms, ±1%  
AC220Vrms, ±1%
- Output Current  
See Table 1
- Output Frequency  
50Hz/60Hz, ±0.1%
- Output Wave, Distortion  
Sine Wave, 1.5% max.
- Output Voltage Temperature Coefficient  
0.02%/°C max.
- Output Frequency Temperature Coefficient  
0.01%/°C max.
- Efficiency  
See Table 1
- Line Regulation  
0.5% max. (at Vin Range)
- Load Regulation  
1% max. (0~100% Load)
- Short Circuit Protection  
Built-in, Auto-restart (See Fig. 2)
- Remote ON/OFF Control  
ON : Short or 0~0.8V  
OFF : Open or 2~10V  
-25°C~+70°C (See Fig. 1)
- Operating Ambient Temperature  
-40°C~+70°C
- Storage Temperature  
-40°C~+70°C
- Isolation Voltage  
AC2000V one minute  
(Input-Output-Case)
- Isolation Impedance  
100MΩ min. (at DC1000V)  
(Input-Output-Case)
- Weight  
4.7kg max.
- Humidity  
20~90% RH
- Shock  
196m/s<sup>2</sup> (11msec 3directions)
- Vibration  
10~55Hz 29.4m/s<sup>2</sup>  
(30minutes 3directions)
- Surface Structure  
Metal Case
- MTBF  
90,000H  
(Ta : 25°C, 80% Load, Nominal Vin)
- Warranty  
5 years

### Terminal Outs & Dimensions (±1.0mm)

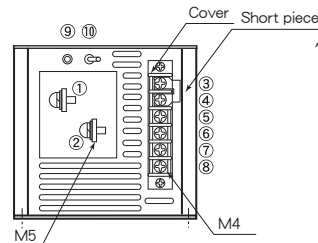
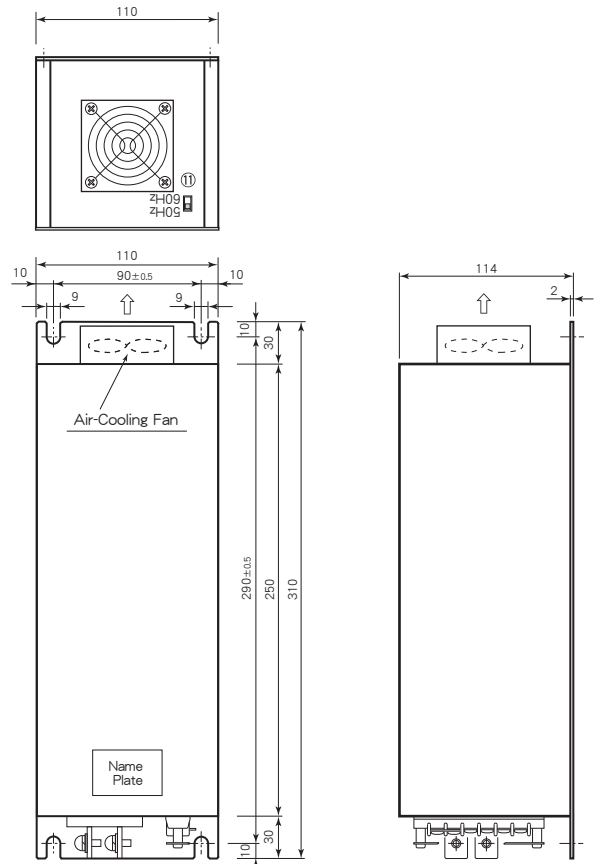

### Terminal Outs and Function

①	+Vdc in
②	0 Vdc in
③	+Remote Control (+RC)
④	-Remote Control (-RC)
⑤	No Connection (NC)
⑥	AC out
⑦	AC out
⑧	Frame Ground (FG)
⑨	Operation Indicator
⑩	ON/OFF Control Switch
⑪	Frequency Changing Switch

### Selection Guide

Table 1

Model Number	Input Volt. (Range) (V. DC)	Output Voltage (V. AC)	Output Current (A rms)	※1 Output Frequency (Hz)	Efficiency (Typical)(%)	
					20% Load	80% Load
RA520-12-100S 4A	12 (9~18)	100	4	50/60	83	86
RA520-12-200S 2A		200	2	50/60	82	86
RA520-12-220S1.8A		220	1.8	50/60	82	86
RA520-24-100S 5A	24 (18~36)	100	5	50/60	83	88
RA520-24-200S2.5A		200	2.5	50/60	82	88
RA520-24-220S2.2A		220	2.2	50/60	82	88
RA520-48-100S 5A	48 (36~76)	100	5	50/60	83	88
RA520-48-200S2.5A		200	2.5	50/60	82	88
RA520-48-220S2.2A		220	2.2	50/60	82	88
RA520-96-100S 5A	96 (72~144)	100	5	50/60	83	88
RA520-96-200S2.5A		200	2.5	50/60	82	88
RA520-96-220S2.2A		220	2.2	50/60	82	88

※1 出力周波数(50Hz又は60Hz)は周波数切替スイッチによって選択可能です。  
Output frequency(50Hz or 60Hz) is selectable by a Frequency Changing Switch.  
※2 上記仕様以外にも対応可能ですので お問い合わせ下さい。  
Please consult with us about other specification.

# RA520 SERIES DATA SHEET

## Block Diagram

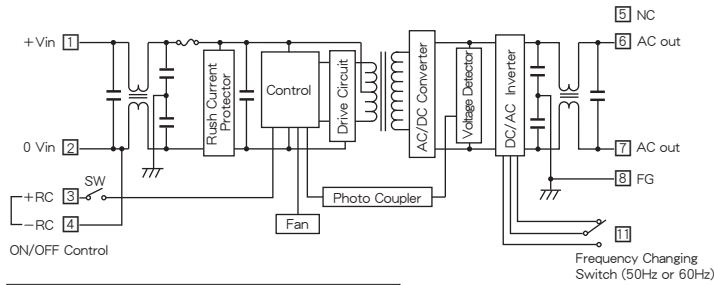

## Characteristic Curves

**Fig. 1 Derating Curve**

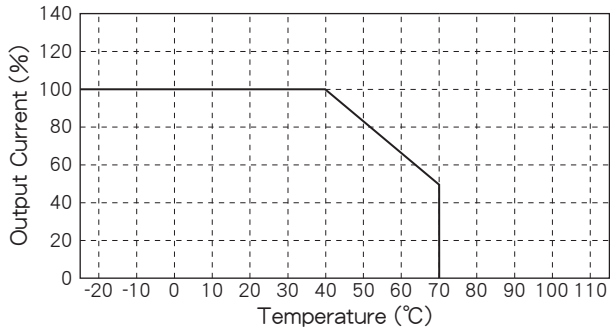

**Fig. 2 Short Circuit Operating Area**

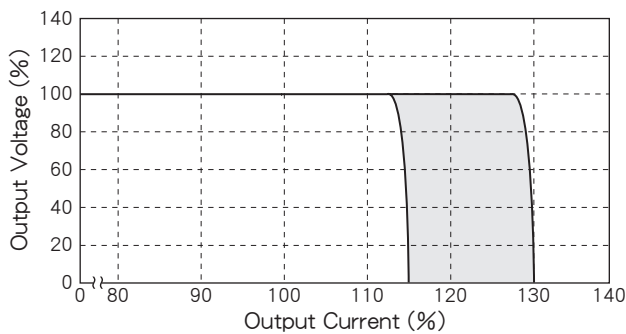

**Fig. 3 Temperature Characteristic on Case Surface**

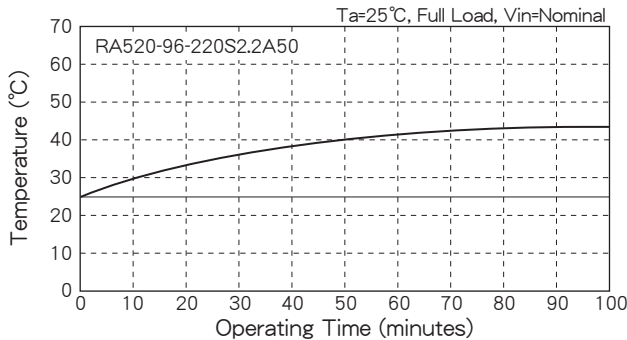

**Fig. 4 Efficiency vs. Output Current**

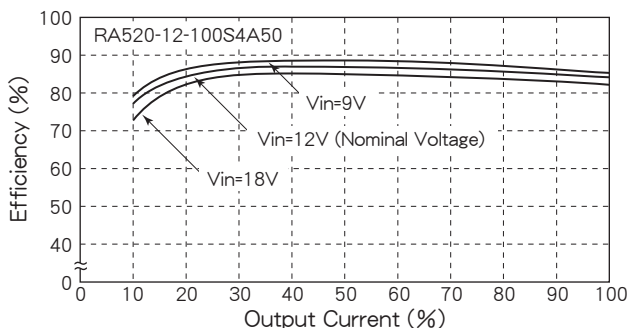

**Fig. 5 Efficiency vs. Output Current**

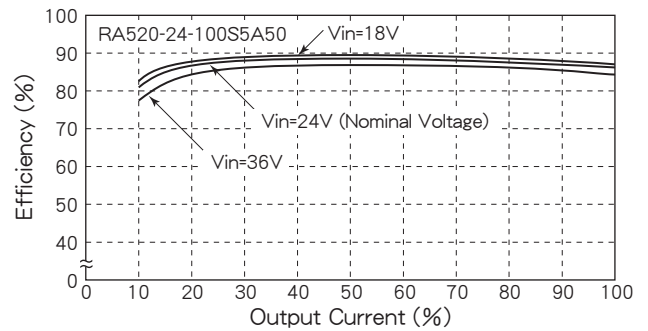

**Fig. 6 Efficiency vs. Output Current**

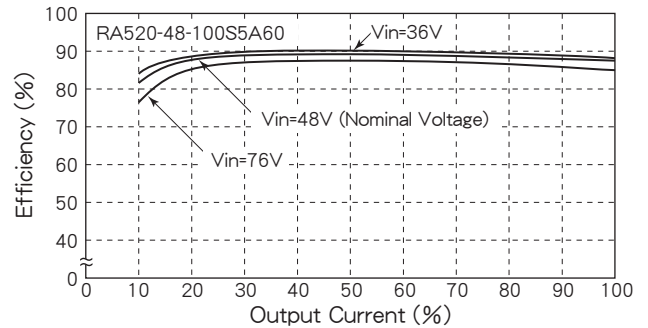

**Fig. 7 Efficiency vs. Output Current**

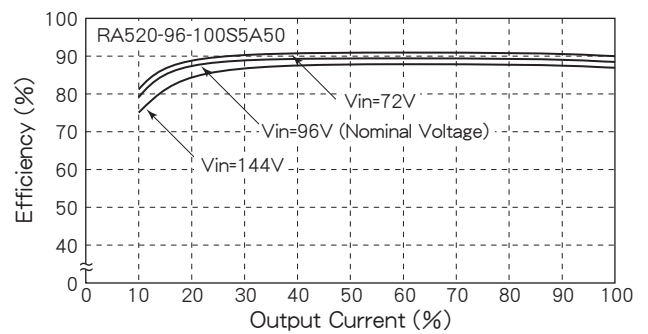

# RA520 SERIES DATA SHEET

## ■ 主な機能及び注意事項 Function and direction in application

1. 入力低電圧保護、入力過電圧保護 Input low/over voltage protection  
 下記入力電圧にて出力電圧がOFFとなります。入力電圧を規定値内に戻すと自動復帰します。  
 Output will be shut down in the input voltages on the following table. Output will automatically be reset when the input voltage comes to within the specified value.

定格入力電圧 Rated input voltage	低電圧保護動作点 Low voltage protection	過電圧保護動作点 Over voltage protection
12V (9~18V)	6~8V	20~22V
24V (18~36V)	12~16V	40~44V
48V (36~76V)	24~32V	80~88V
96V (72~144V)	48~64V	150~165V

2. 出力過電流保護 Output over current protection  
 負荷が短絡した場合など、過大な負荷電流が流れたときに負荷と本体を保護する機能です。定格出力電流の約115%~130%にて検出し作動します(Fig. 2 参照)。出力は定電流電圧垂下特性、入力電流はフの字特性となっています。また自動復帰特性を有しています。  
 This function is to protect a power supply and a load when excessive current flows in case of short-circuited load or such possible conditions. It will operate in 115%~130% of rated output current (see Fig. 2). Output has constant current voltage limiting characteristic and input current has combined current limiting with fold-back protection. It also has automatic reset function.

3. 過熱保護 Thermal protection  
 本体内部に過熱保護回路が内蔵されています。内部温度が+90℃~+110℃にて出力が停止します。+90℃以下で自動復帰します。  
 Thermal protection is built-in. Output will be shut down in +90~+110℃ at the plate inside and will automatically be reset below +90℃.

4. リモートON/OFFコントロール Remote ON/OFF control  
 リモートON/OFFコントロールを使用して、電源の出力をON/OFFする事ができます。RC端子間をショートする事で出力電圧がON、RC端子間をオープンにする事で出力電圧がOFFになります。RC端子間にTTLレベルの電気信号を加える事により出力をON/OFFする事ができます。またRC端子間をショートしたままスイッチを手動でON/OFFする事により、出力電圧をON/OFFできます。RC端子は入力側にあり、入力電源回路とは絶縁されていません。  
 Using remote ON/OFF control, ON/OFF of the power supply output is possible. The output voltage operates by a short between RC terminals, and the output voltage stops by open between RC terminals. ON/OFF of the output voltage is possible by adding the electrical signal of the TTL level between RC terminals. In addition, ON/OFF of the output voltage is possible by performing ON/OFF of the switch on front panel by manual operation with short between RC terminals. RC terminals are located on the input side and the circuit is not isolated from input power source circuit.

5. ファンの作動 Cooling fan operation  
 冷却ファンは入力電圧が印加され、さらに内部温度が+45℃以上に作動します。従って、入力を印加した直後ではファンは作動しません。作動までの時間は負荷の条件により異なります。全負荷の場合は約10分後に作動します。  
 It will operate when input voltage is applied and inner temperature is getting more than +45℃. Therefore it does not operate right after input voltage is applied. Time to operate depends on load conditions. In case of 100% load, it would be approximately 10 minutes.

6. 出力側突入電流保護 Output rush current protection  
 出力側の負荷としてダイオードで整流されたC負荷の突入電流に対して、問題なくインバータは動作します。  
 Inverter operates unconditionally against rush current of capacitor load rectified by diodes.

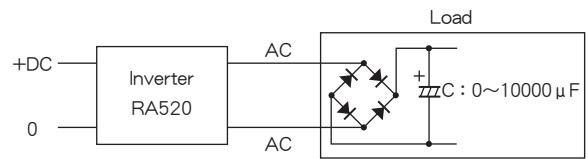

### ●TRIによる例 Example by transistor

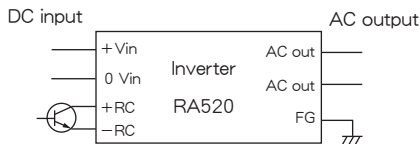

### ●SWによる例 Example by switch

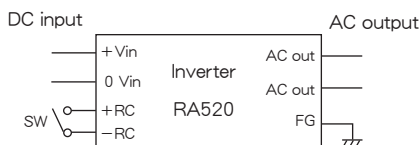

**RA520 SERIES DATA SHEET**