

VA500 SERIES

400~500VA DC/AC INVERTERS Sine Wave Output



H60×W120×L220 (mm)

Features

- High Efficiency 86~88% typical
 - Vertical, Horizontal Mount
 - Remote ON/OFF Control
 - Input Low Voltage Protection
 - Input Over Voltage Protection
 - Thermal Protection
+110°C~+120°C
 - Output Frequency Temp. Coefficient
0.01%/°C max.
 - Input-Output Isolation (AC2000V)
 - Operating Ambient Temperature
-40°C~+85°C
 - Built-in Output Noise Filter
 - Built-in Input Fuse
 - Built-in Frequency Changing Switch
(50Hz or 60Hz)
 - Conformity to RoHS2 Directive
 - Not built-in aluminum and tantalum electrolytic capacitor
- 高効率 86~88% typical
 - 縦置き、横置き共用
 - リモートON/OFFコントロール
 - 入力低電圧保護回路内蔵
 - 入力過電圧保護回路内蔵
 - 過熱保護回路内蔵
+110°C~+120°C
 - 出力周波数温度係数
0.01%/°C 以下
 - 入出力間絶縁 (AC2000V)
 - 動作周囲温度
-40°C~+85°C
 - 出力ノイズフィルタ内蔵
 - 入力ヒューズ内蔵
 - 周波数切替スイッチ有り
(50Hz又は60Hz)
 - RoHS2指令対応
 - アルミ電解コンデンサ及びタンタルコンデンサ不使用

General Characteristics

- Input Voltage (at Ta : 25°C, Full Load, Nominal Vin)
DC12, 24, 48, 96, 200, 300, 400V
(See Table 1)
- Output Voltage
AC100Vrms, ±1%
AC200Vrms, ±1%
AC220Vrms, ±1%
See Table 1
- Output Current
50Hz/60Hz, ±0.1%
- Output Wave, Distortion
Sine Wave, 1.5% max.
- Output Voltage Temperature Coefficient
0.02%/°C max.
- Output Frequency Temperature Coefficient
0.01%/°C max.
- Efficiency
See Table 1
- Line Regulation
0.5% max. (at Vin Range)
- Load Regulation
1% max. (0~100% Load)
- Short Circuit Protection
Built-in, Auto-restart (See Fig. 2)
- Remote ON/OFF Control
ON : Short or 0~0.8V
OFF : Open or 2~10V
-40°C~+85°C (See Fig. 1)
- Operating Ambient Temperature
+105°C
- Max. Case Temp.
-40°C~+115°C
- Storage Temperature
AC2000V one minute
(Input-Output-Case)
- Isolation Voltage
100MΩ min. (at DC1000V)
(Input-Output-Case)
- Isolation Impedance
- Weight
Main Body : 3.9kg max.
Heat Sink : 900g max.
- Humidity
20~90% RH
- Shock
490m/s² (11msec 3directions)
- Vibration
10~55Hz 98m/s²
(30minutes 3directions)
- Surface Structure
Aluminum Case
- MTBF
90,000H
(Ta : 25°C, 80% Load, Nominal Vin)
- Warranty
5 years

Terminal Outs & Dimensions (±1.0mm)

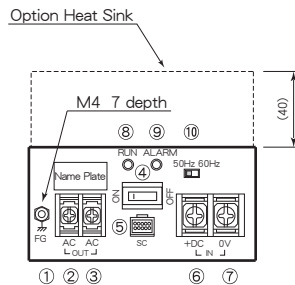
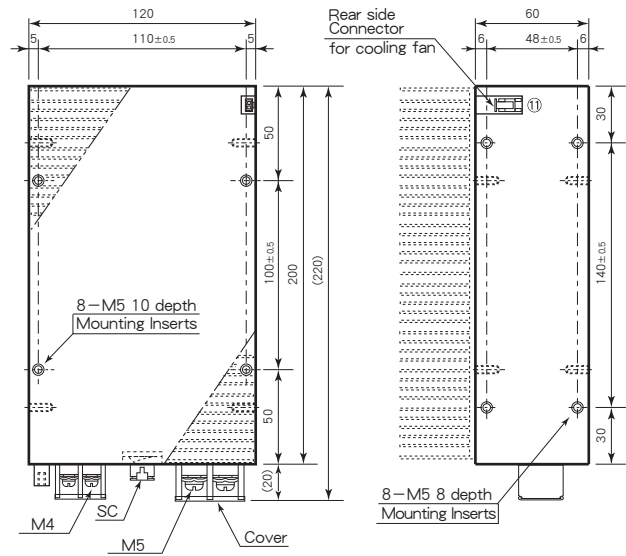

* Option Heat Sink Model : A3-13270

Terminal Outs

①	Frame Ground (FG)
②	AC out
③	AC out
④	ON/OFF Switch
⑤	Signal Connector
⑥	+ Vdc in
⑦	0 Vdc in
⑧	Operation Indicator
⑨	Alarm Indicator
⑩	Frequency Changing Switch
⑪	Rear side Connector

Selection Guide

Table 1

Model Number	Input Volt. (Range) (V. DC)	Output Voltage (V. AC)	Output Current (A rms)	Output Frequency (Hz)	Efficiency (typ.) (%)	
					20% Load	80% Load
VA500-12 - 100S 4A	12 (9~18)	100	4	50/60	85	86
VA500-12 - 200S 2A		200	2	50/60	83	86
VA500-12 - 220S1.8A		220	1.8	50/60	83	86
VA500-24 - 100S 5A	24 (18~36)	100	5	50/60	86	88
VA500-24 - 200S2.5A		200	2.5	50/60	83	88
VA500-24 - 220S2.2A		220	2.2	50/60	83	88
VA500-48 - 100S 5A	48 (36~76)	100	5	50/60	86	88
VA500-48 - 200S2.5A		200	2.5	50/60	83	88
VA500-48 - 220S2.2A		220	2.2	50/60	83	88
VA500-96 - 100S 5A	96 (72~144)	100	5	50/60	86	88
VA500-96 - 200S2.5A		200	2.5	50/60	83	88
VA500-96 - 220S2.2A		220	2.2	50/60	83	88
VA500-200-100S 5A	200 (150~300)	100	5	50/60	86	88
VA500-200-200S2.5A		200	2.5	50/60	83	88
VA500-200-220S2.2A		220	2.2	50/60	83	88
VA500-300-100S 5A	300 (225~450)	100	5	50/60	86	88
VA500-300-200S2.5A		200	2.5	50/60	83	88
VA500-300-220S2.2A		220	2.2	50/60	83	88
VA500-400-100S 5A	400 (300~600)	100	5	50/60	86	88
VA500-400-200S2.5A		200	2.5	50/60	83	88
VA500-400-220S2.2A		220	2.2	50/60	83	88

※1 出力周波数(50Hz又は60Hz)は周波数切替スイッチによって選択可能です。
Output frequency(50Hz or 60Hz) is selectable by a Frequency Changing Switch.
※2 上記仕様以外にも対応可能ですので お問い合わせ下さい。
Please consult with us about other specification.

VA500 SERIES DATA SHEET

Block Diagram

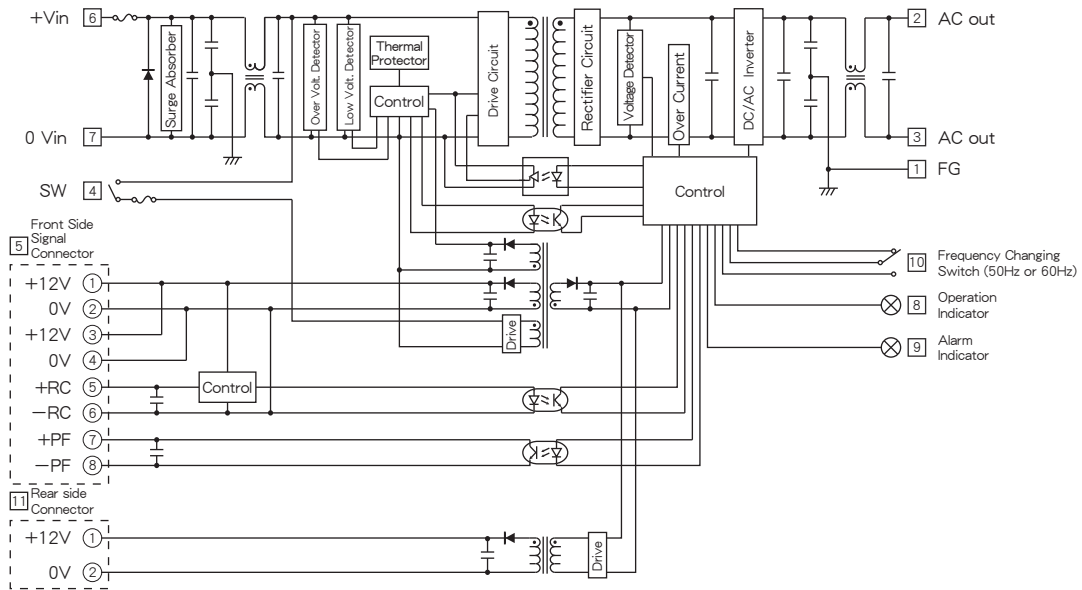

Connector Pin Out

Front side Signal Connector Pin Outs

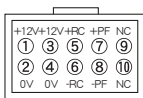

Mating connector : PADP-10V-1-S (J.S.T)
Terminal : SPH-001T-P0.5L (J.S.T)

- ① Stand-by source (+12V, 0.05A)
- ② Stand-by source (0V)
- ③ Stand-by source (+12V, 0.05A)
- ④ Stand-by source (0V)
- ⑤ Remote Control (+)
- ⑥ Remote Control (-)
- ⑦ Power Fail (+)
- ⑧ Power Fail (-)
- ⑨ No Connection
- ⑩ No Connection

Rear side Connector Pin Outs



Mating connector : PAP-02V-S (J.S.T)
Terminal : SPHD-001T-P0.5 (J.S.T)

- ① Stand-by source (+12V, 0.2A)
- ② Stand-by source (0V)

VA500 SERIES DATA SHEET

Characteristic Curves

Fig. 1 Derating Curve

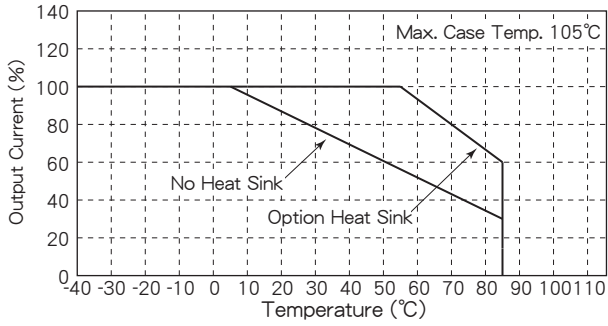

Fig. 2 Short Circuit Operating Area

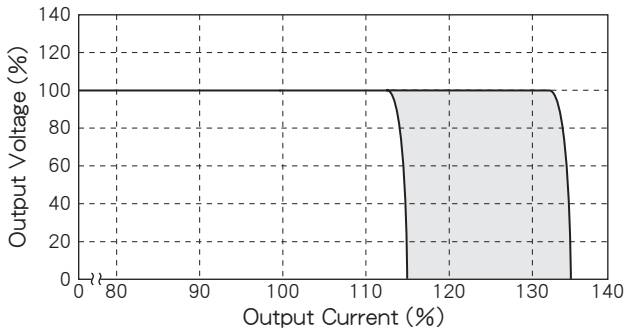

Fig. 3 Temperature Characteristic on Case Surface

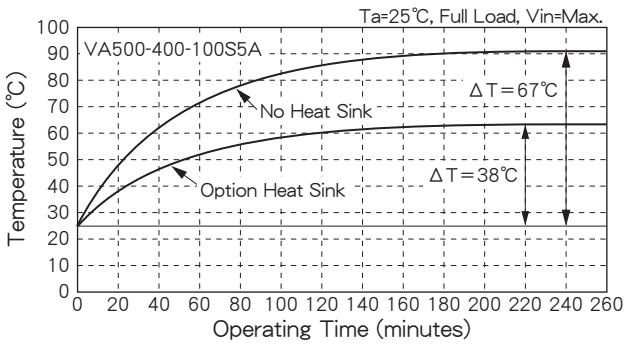

Fig. 4 Efficiency vs. Output Current

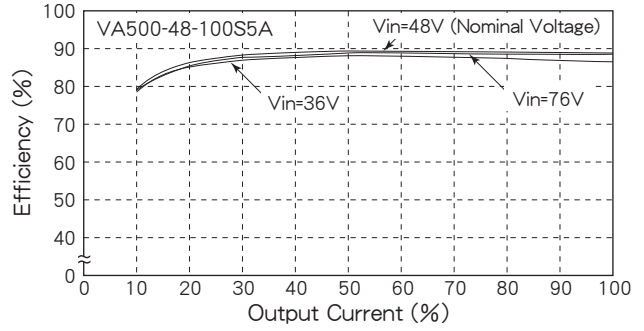
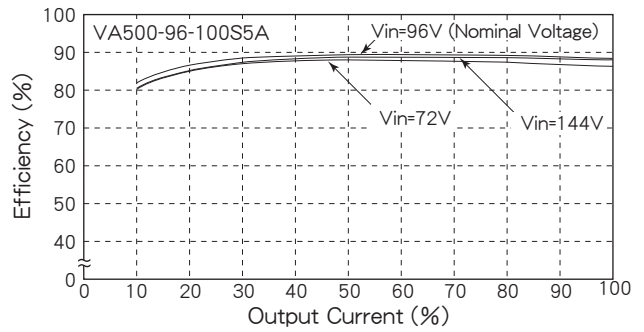

Fig. 5 Efficiency vs. Output Current



VA500 SERIES DATA SHEET

■ 主な機能及び注意事項 Function and direction in application

1. 入力低電圧保護、入力過電圧保護 Input low/over voltage protection
 下記入力電圧にて出力電圧がOFFとなります。入力電圧を規定値内に戻すと自動復帰します。
 Output will be shut down in the input voltages on the following table. Output will automatically be reset when the input voltage comes to within the specified value.

定格入力電圧 Rated input voltage	低電圧保護動作点 Low voltage protection	過電圧保護動作点 Over voltage protection
12V (9~18V)	6~8V	20~22V
24V (18~36V)	12~16V	40~44V
48V (36~76V)	24~32V	80~88V
96V (72~144V)	48~64V	152~168V
200V (150~300V)	102~133V	316~330V
300V (225~450V)	153~200V	474~495V
400V (300~600V)	204~265V	633~660V

2. 出力過電流保護 Output over current protection
 負荷が短絡した場合など、過大な負荷電流が流れたときに負荷と本体を保護する機能です。定格出力電流の約115%~135%にて検出し作動します(Fig. 2 参照)。出力は定電流電圧垂下特性、入力電流はフの字特性となっています。また自動復帰特性を有しています。
 This function is to protect a power supply and a load when excessive current flows in case of short-circuited load or such possible conditions. It will operate in 115%~135% of rated output current (see Fig. 2). Output has constant current voltage limiting characteristic and input current has combined current limiting with fold-back protection. It also has automatic reset function.
3. 過熱保護 Thermal protection
 本体内部に過熱保護回路が内蔵されています。内部温度が+110°C~+120°Cにて出力が停止します。+110°C以下で自動復帰します。
 Thermal protection is built-in. Output will be shut down in +110 - 120°C at the plate inside and will automatically be reset below +110°C.

4. リモートON/OFFコントロール Remote ON/OFF control
 リモートON/OFFコントロールを使用して、電源の出力をON/OFFすることができます。RC端子間をショートする事で出力電圧がON、RC端子間をオープンにする事で出力電圧がOFFになります。RC端子間にTTLレベルの電気信号を加える事により出力をON/OFFすることができます。またRC端子間をショートしたままスイッチを手動でON/OFFする事により、出力電圧をON/OFFできます。RC端子は、入力、出力、FG端子、PF端子、リアサイドコネクタ端子と絶縁されています。
 Using remote ON/OFF control, ON/OFF of the power supply output is possible. The output voltage operates by a short between RC terminals, and the output voltage stops by open between RC terminals. ON/OFF of the output voltage is possible by adding the electrical signal of the TTL level between RC terminals. In addition, ON/OFF of the output voltage is possible by performing ON/OFF of the switch on front panel by manual operation with short between RC terminals. RC terminals are isolated from input, output, FG terminal, PF terminal and rear side connector terminal.

●TRIによる例 Example by transistor

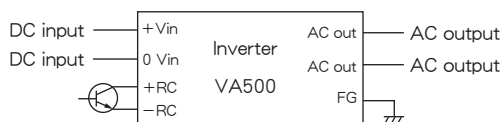

●SWによる例 Example by switch

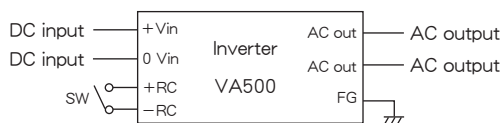

5. 出力側突入電流保護 Output rush current protection
 出力側の負荷としてダイオードで整流されたC負荷の突入電流に対して、問題なくインバータは動作します。
 Inverter operates unconditionally against rush current of capacitor load rectified by diodes.

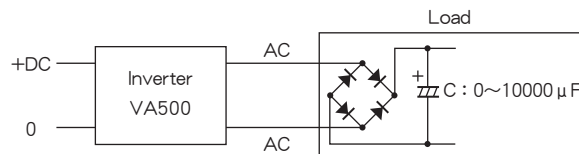

6. PF端子 (オープンコレクタ方式) PF terminals (Open collector method)

PF端子は、以下の保護が動作した場合に"Open"になります。

- 入力低電圧保護
- 入力過電圧保護
- 出力過電流保護
- 過熱保護

電源正常時はPF端子が"Short"になります。

PF端子は、入力、出力、FG端子、RC端子、リアサイドコネクタ端子と絶縁されています。

When the following protection operates, the PF terminal outputs "Open".

- Input low voltage protection
- Input over voltage protection
- Output over current protection
- Thermal protection

The PF terminal outputs "Short" in the power supply normalcy.

PF terminal is isolated from input, output, FG terminal and rear side connector terminal.

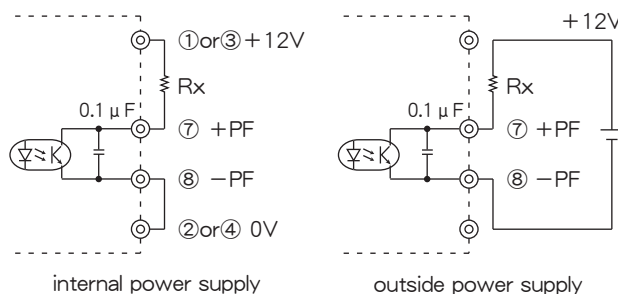

7. リアサイドDC12V 0.2A電源コネクタ端子

Rear side DC12V 0.2A power supply connector terminal
 リアサイドコネクタ端子のDC12V出力は、放熱効果をも高める為の外付け冷却ファン用の電源に使うことができます。リアサイドコネクタ端子は、入力、出力、FG端子、RC端子、PF端子と絶縁されています。

Possible to use the DC12V output of the rear side connector terminal as a power supply for external cooling fans to add a heat radiation effect. Rear side connector terminal is isolated from input, output, FG terminal, RC terminal and PF terminal.