

KM SERIES

105~200W DC/DC CONVERTERS 並列運転可能 Parallel Operation

KMU type



H20×W60×L135 (mm)

KMS type



H20×W60×L135 (mm)

Features

- Built-in Input Filter
- Input-Output Isolation
- High Efficiency 87~91%
- Wide Input Voltage Range
- High Reliability
- Adjustable Output Volt. ±10%
- Input Low Voltage Protection
- Input Over Voltage Protection
- Output Over Voltage Protection
- Thermal Protection
+110°C~+120°C
- Remote ON/OFF Control
- Possible Parallel Operation
up to 3 converters
- Operating Ambient Temperature
-40°C~+85°C
- Conformity to RoHS2 Directive
- Not built-in aluminum and
tantalum electrolytic capacitor
- 入力フィルタ内蔵
- 入出力間絶縁
- 高効率 87~91%
- 広範囲な入力電圧
- 高信頼性
- 可変出力電圧 ±10%
- 入力低電圧保護回路内蔵
- 入力過電圧保護回路内蔵
- 出力過電圧保護回路内蔵
- 過熱保護回路内蔵
+110°C~+120°C
- リモートON/OFFコントロール
- 3台まで並列運転可能
- 動作周囲温度
-40°C~+85°C
- RoHS2指令対応
- アルミ電解コンデンサ及び
タンタルコンデンサ不使用

General Characteristics

- Input Voltage, Range DC12, 24, 48, 100, 140V (See Table 1)
- Output Voltage, Current See Table 1
- Output Voltage Range ±10% Adjustable
- Efficiency See Table 1
- Line Regulation ±0.3% max. (at Vin Range)
- Load Regulation 3% max. (0~100% Load) (See Fig. 6)
- Reflected Input Ripple, Noise (5% Vin) Vp-p max.
- Output Ripple 80mVp-p max.
- Output Noise (0.5% Vout+100mV) p-p max.
- Short Circuit Protection Built-in, Auto-restart (See Fig. 5)
- Over Voltage Protection 115~140% Output Voltage
- Remote ON/OFF Control ON : Short or 0~0.8V
OFF : Open or 2~10V
(Between terminal ② ~ ③)
- Temperature Coefficient 0.02%/°C max.
- Operating Ambient Temp. -40°C~+85°C (See Fig. 1)
- Max. Case Temperature +105°C
- Storage Temperature -55°C~+125°C
- Isolation Voltage AC2000V one minute
(Input-Output-Case)
- Isolation Impedance 100MΩ min. (at DC1000V)
(Input-Output-Case)
- Weight Main Body : 350g max.
Heat Sink
A3-13910 : 135g max.
A3-13911 : 175g max.
A3-13915 : 425g max.
- Humidity 20~95% RH
- Shock 490m/s² (11msec 3directions)
- Vibration 10~55Hz 98m/s²
(30minutes 3directions)
- Surface Structure Aluminum Case
- MTBF 400,000H
(Ta : 25°C, 80% Load, Nominal Vin)
- Warranty 5 years

Option Heat Sink

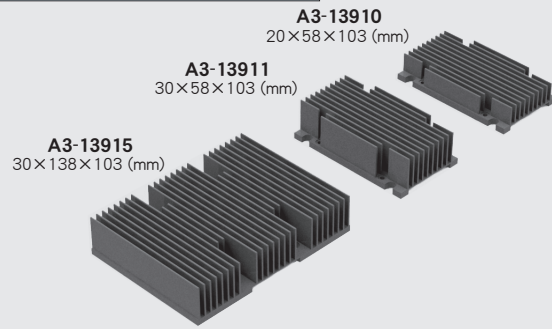

Selection Guide

Table 1

Model Number	Input Volt. (Range) (V. DC)	Output Voltage (V. DC)	Output Current (A)	Efficiency (Typical)(%)		
				20% Load	50% Load	80% Load
KMU(KMS) 12- 3.3S 32A	12 (8~18)	3.3	32	85	88	87
		5	28	86	90	88
		6	23.3	86	90	88
		12	13.4	87	90	89
		13.8	11.6	87	90	89
		15	10.7	87	90	89
	at 100% Load	24	6.7	87	90	89
		28	5.8	87	90	89
		48	3.4	87	90	89
		3.3	40	88	91	90
		5	32	90	92	91
		6	26.6	90	92	91
KMU(KMS) 24- 5S 32A	24 (16~36)	12	16.7	90	92	91
		13.8	14.5	90	92	91
		15	13.4	90	92	91
		24	8.4	90	92	91
		28	7.2	90	92	91
		48	4.2	90	92	91
	48 (36~76)	3.3	40	88	91	90
		5	32	91	92	91
		6	26.6	91	92	91
		12	16.7	91	92	91
		13.8	14.5	91	92	91
		15	13.4	91	92	91
KMU(KMS) 48- 6S 26.6A	100 (64~144)	24	8.4	91	92	91
		28	7.2	91	92	91
		48	4.2	91	92	91
		3.3	40	85	91	90
		5	32	87	92	91
		6	26.6	87	92	91
	140 (90~200)	12	16.7	87	92	91
		13.8	14.5	87	92	91
		15	13.4	87	92	91
		24	8.4	87	92	91
		28	7.2	87	92	91
		48	4.2	87	92	91

* 上記仕様以外にも対応可能ですのでお問い合わせください。
Please consult with us about other specification.

KM SERIES DATA SHEET

Terminal Outs & Dimensions (±0.5mm)

KMU type

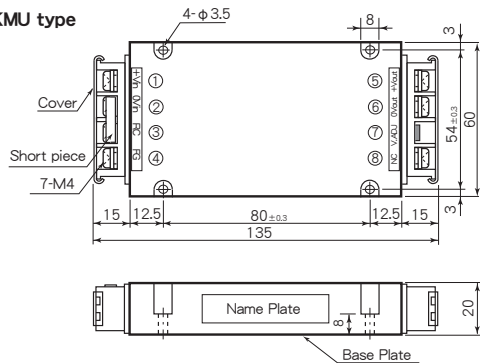

Terminal Outs

①	+Vdc in
②	0 Vdc in
③	RC
④	FG
⑤	+Vdc out
⑥	0 Vdc out
⑦	V. ADJ
⑧	NC

⊗ Voltage Adjustable Trimmer

KMS type

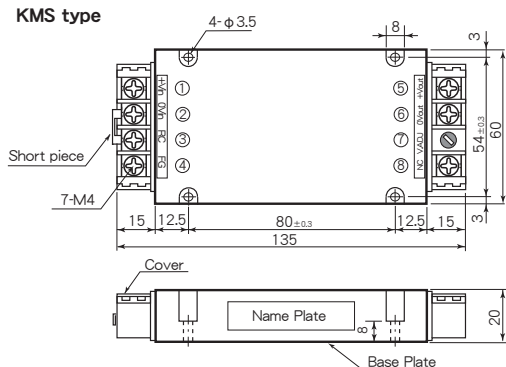

Terminal Outs

①	+Vdc in
②	0 Vdc in
③	RC
④	FG
⑤	+Vdc out
⑥	0 Vdc out
⑦	V. ADJ
⑧	NC

⊗ Voltage Adjustable Trimmer

Block Diagram

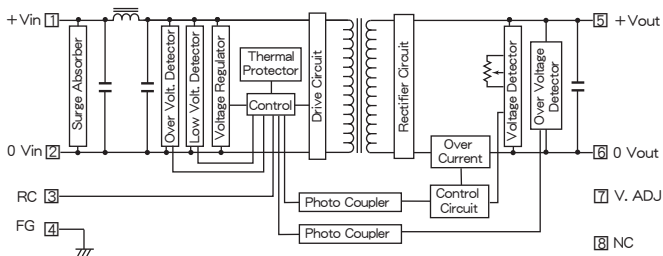

Characteristic Curves

Fig. 1 Derating Curve

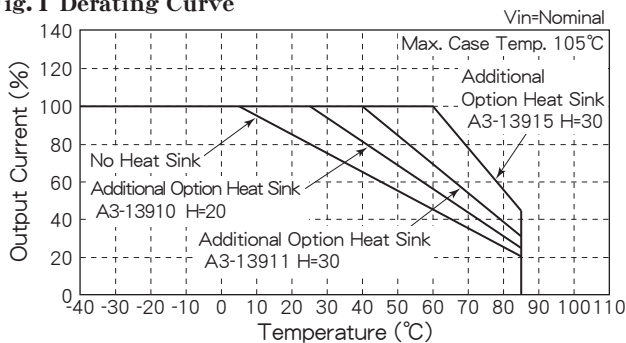

Option Heat Sink

Fig. 2 Temperature Characteristic on Case Surface

*Option Heat Sink Model : A3-13910

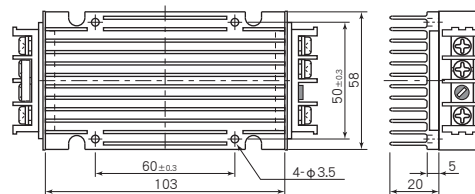

KMU24-12S16.7A Additional Heat Sink A3-13910
Ta=25°C, 100% Load, Vin=Nominal

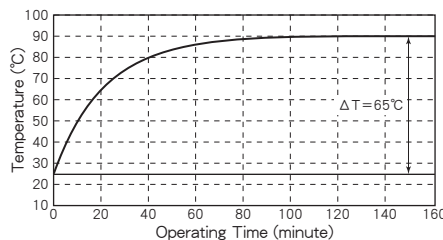
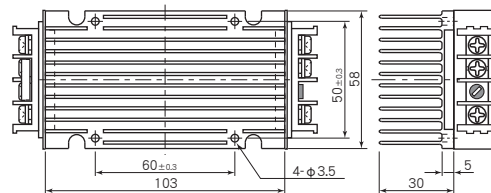

Fig. 3 Temperature Characteristic on Case Surface

*Option Heat Sink Model : A3-13911



KMU24-12S16.7A Additional Heat Sink A3-13911
Ta=25°C, 100% Load, Vin=Nominal

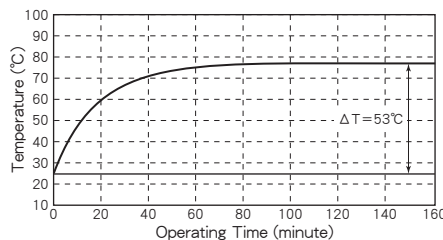
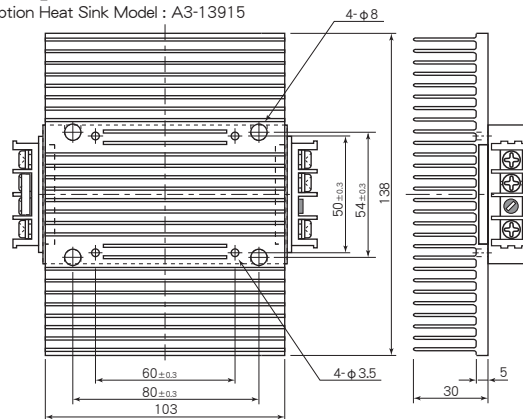
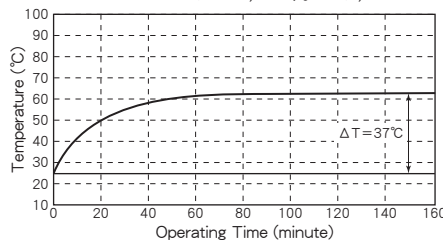

Fig. 4 Temperature Characteristic on Case Surface

*Option Heat Sink Model : A3-13915



KMU24-12S16.7A Additional Heat Sink A3-13915
Ta=25°C, 100% Load, Vin=Nominal



KM SERIES DATA SHEET

Characteristic Curves

Fig. 5 Short Circuit Operating Area

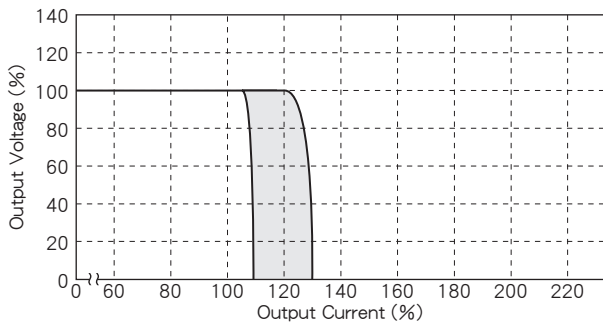
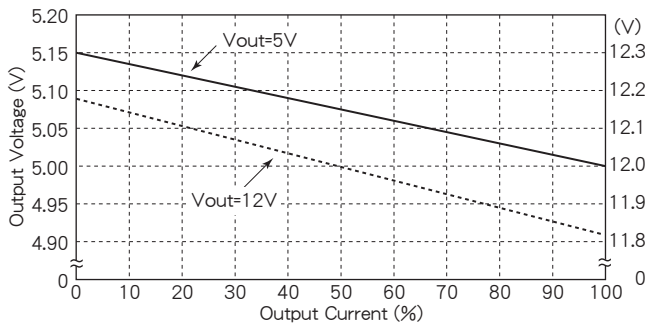

Fig. 6 Output Voltage vs. Output Current



* 並列運転時に各モジュールの電流を平均化するため
 負荷変動を大きくしてあります。
 Load Regulation is regulated large on purpose to equate
 the each unit's output current at parallel operation.

Fig. 7 Efficiency vs. Output Current

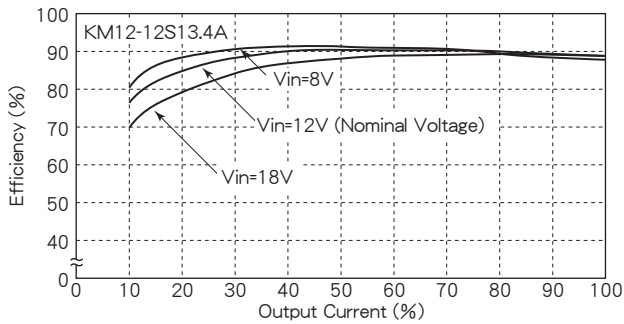

Fig. 8 Efficiency vs. Output Current

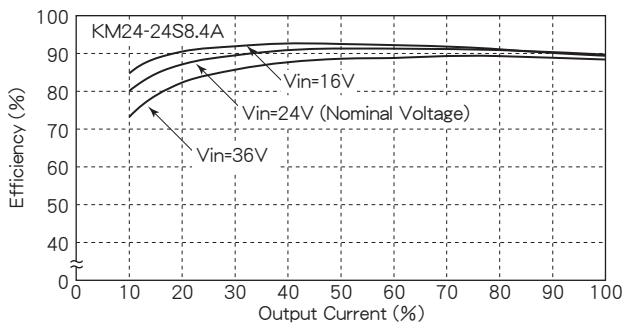

Fig. 9 Efficiency vs. Output Current

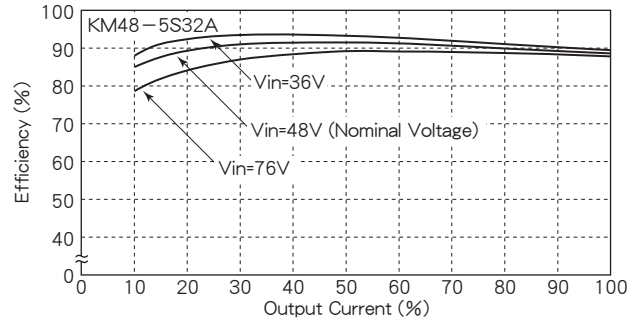

Fig. 10 Efficiency vs. Output Current

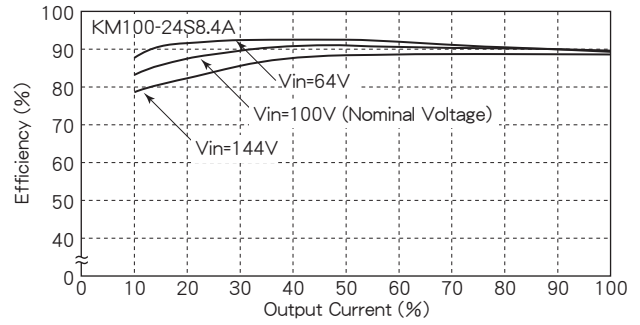
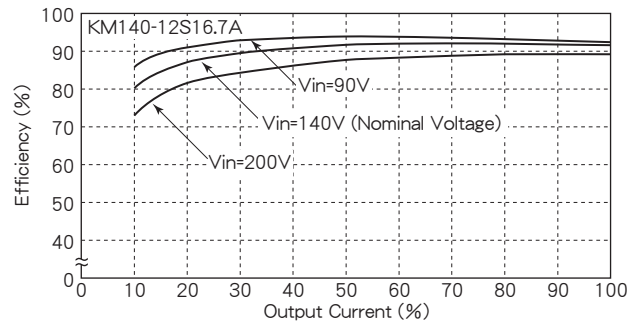

Fig. 11 Efficiency vs. Output Current



■ Parallel Operation

同機種を並列に動作させることにより、出力電流容量を増やすことができます。下図のように結線し、各コンバータ間の出力電圧を同じ電圧に調整することで、並列運転ができます。(Fig. 12を御参照ください)

It is possible to increase output current capacity by parallel operation of the same model. Please see the below figure for wiring instruction. Parallel operation is possible by each outputs to be same voltage.

Fig. 12 Parallel Operation Connection

